

SCALE 0.150

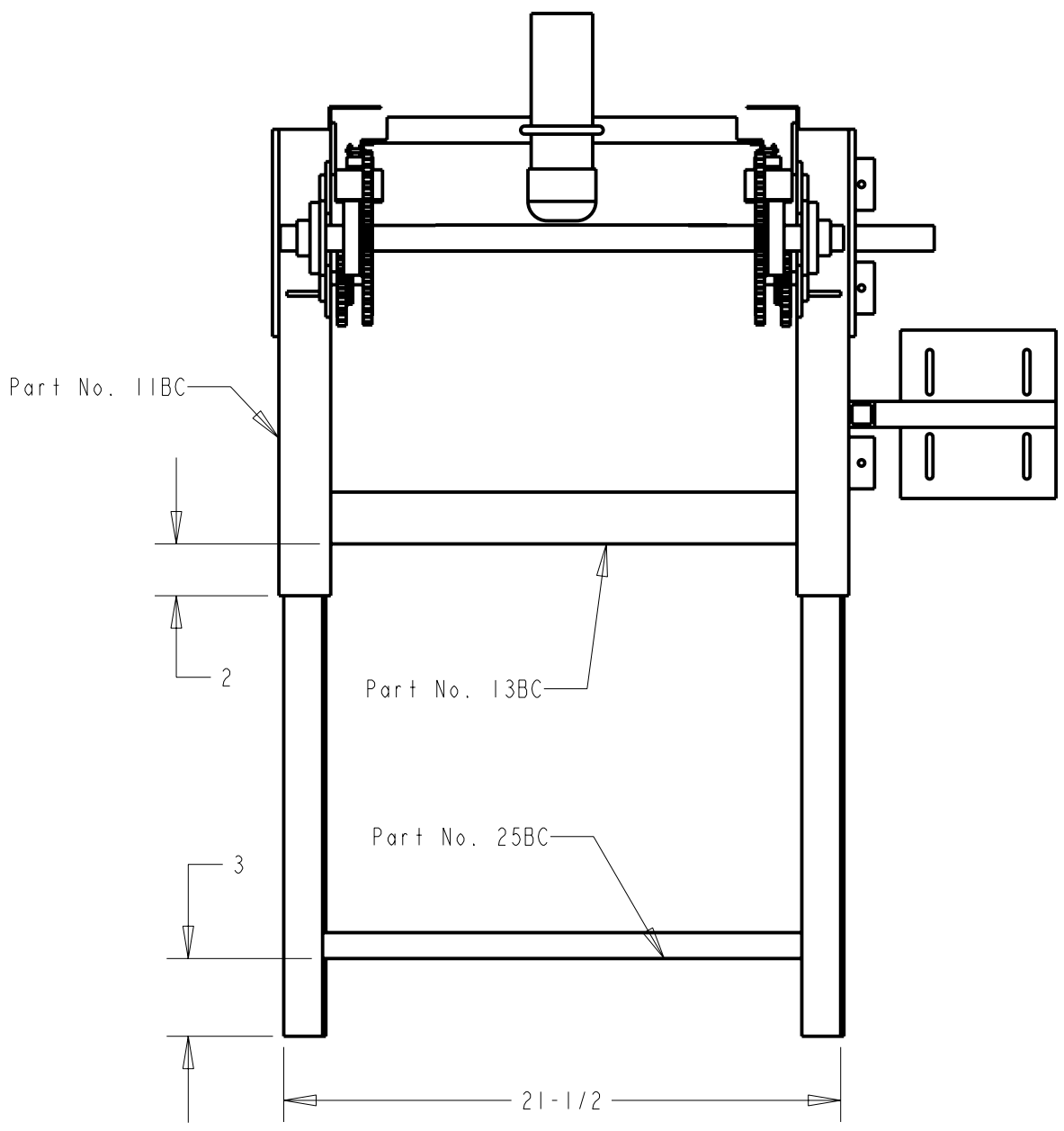

Front View

All Dimensions In Inches

NCSU BAE	Date: 3-17-06	DWG# A1cBC	All Dimensions In Inches	
Project: Burley Stripping Conveyor		Dr By: Justin Macialek		Part No. A1
Part Name: Conveyor Assembly		Tolerances x.xx ±.02, x.xxx± .005		Qty. Required: 1
Rev. 3-17-06				

DETAIL A  
SCALE 0.350

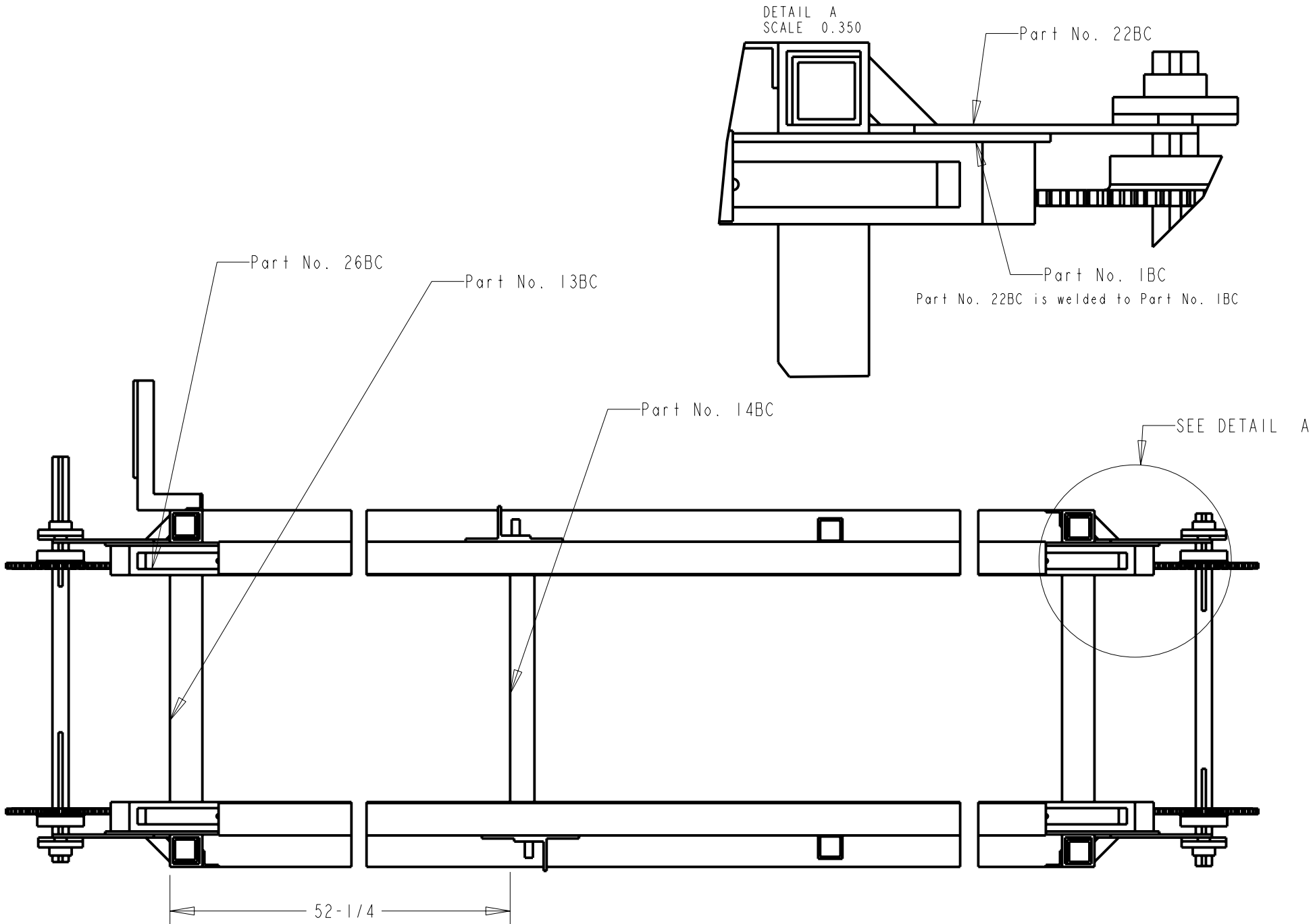

Part No. 22BC  
Part No. 1BC  
Part No. 22BC is welded to Part No. 1BC

Part No. 26BC  
Part No. 13BC

Part No. 14BC

SEE DETAIL A

52-1/4

Top View

NCSU BAE      Date: 3-17-06      DWG# A1bBC

All Dimensions In Inches

Project: Burley Stripping Conveyor

Dr By: Justin Macialek

Part No. A1

Rev. 3-17-06

Part Name: Conveyor Assembly

Tolerances x.xx ±.02, x.xxx± .005

Qty. Required: 1

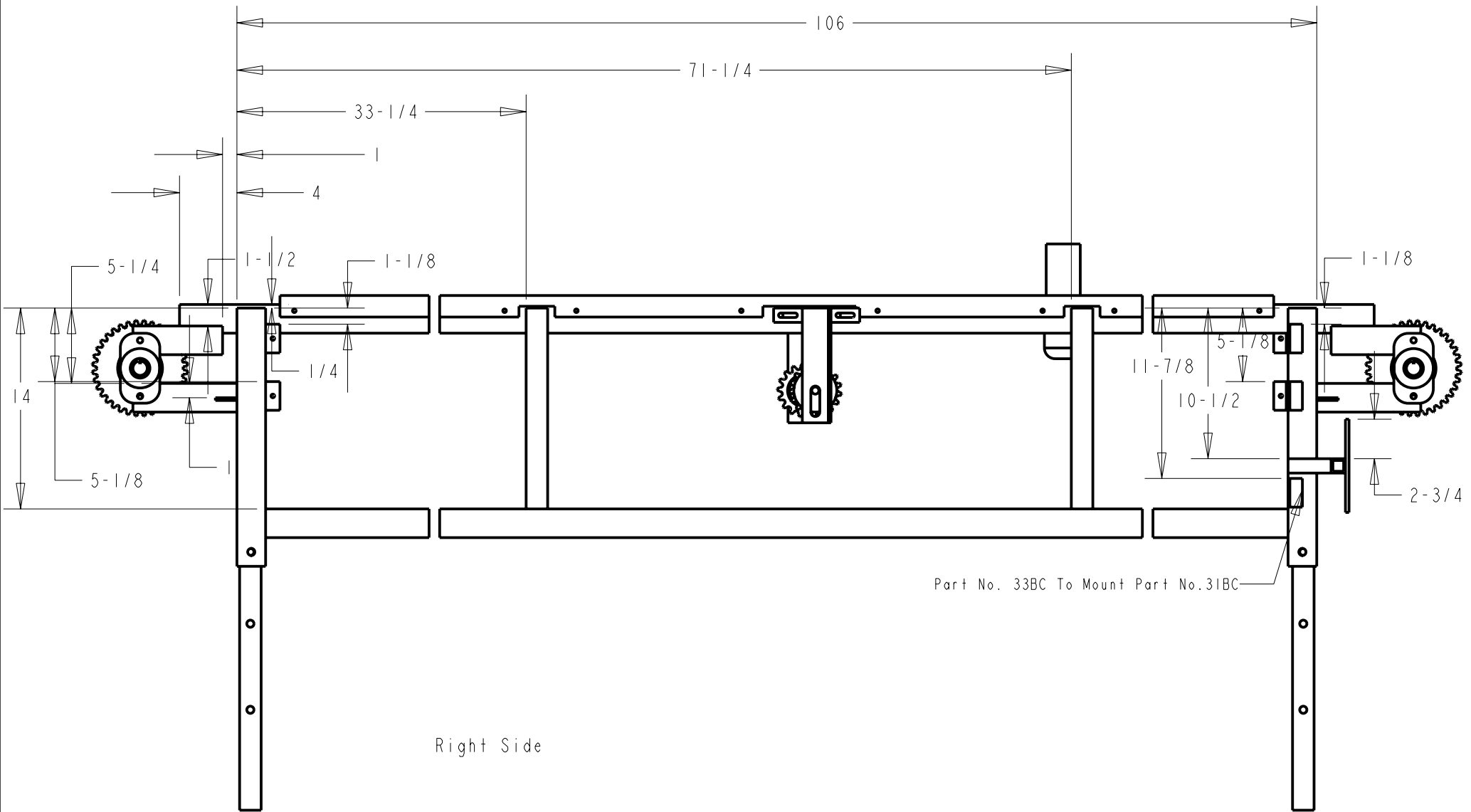

NCSU BAE	Date: 3-17-06	DWG# A1aBC
----------	---------------	------------

All Dimensions In Inches

Project: Burley Stripping Conveyor
------------------------------------

Dr By: Justin Macialek
------------------------

Part No. A1
-------------

Rev. 3-17-06
--------------

Part Name: Conveyor Assembly
------------------------------

Tolerances x.xx ±.02, x.xxx± .005
-----------------------------------

Qty. Required: 1
------------------

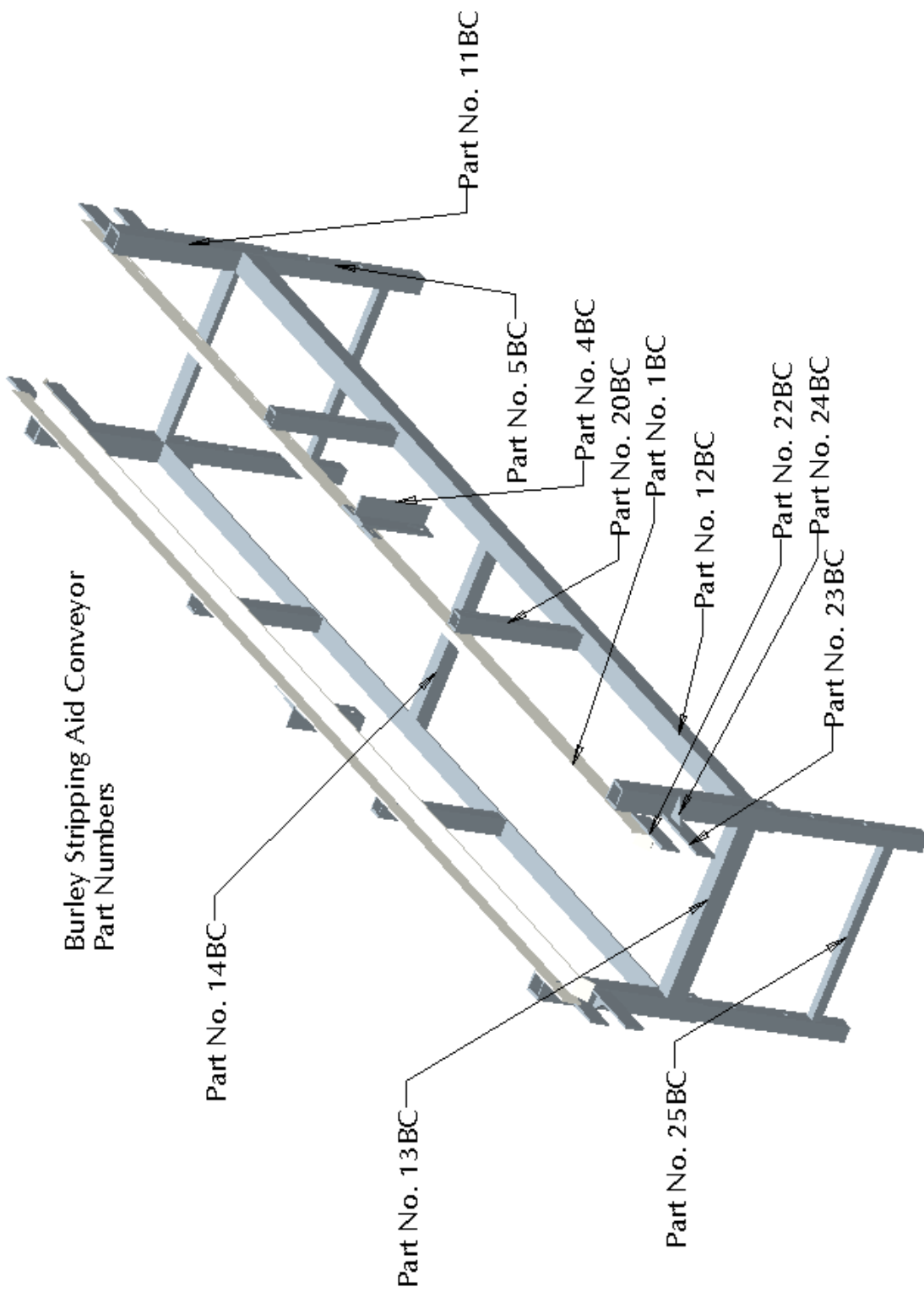

**Burley Stripping Aid Conveyor  
Part Numbers**

Part No. 14BC

Part No. 13BC

Part No. 25BC

Part No. 11BC

Part No. 5BC

Part No. 4BC

Part No. 20BC

Part No. 1BC

Part No. 12BC

Part No. 22BC

Part No. 24BC

Part No. 23BC

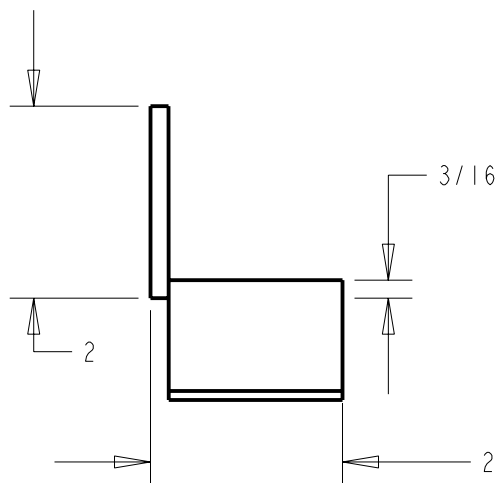
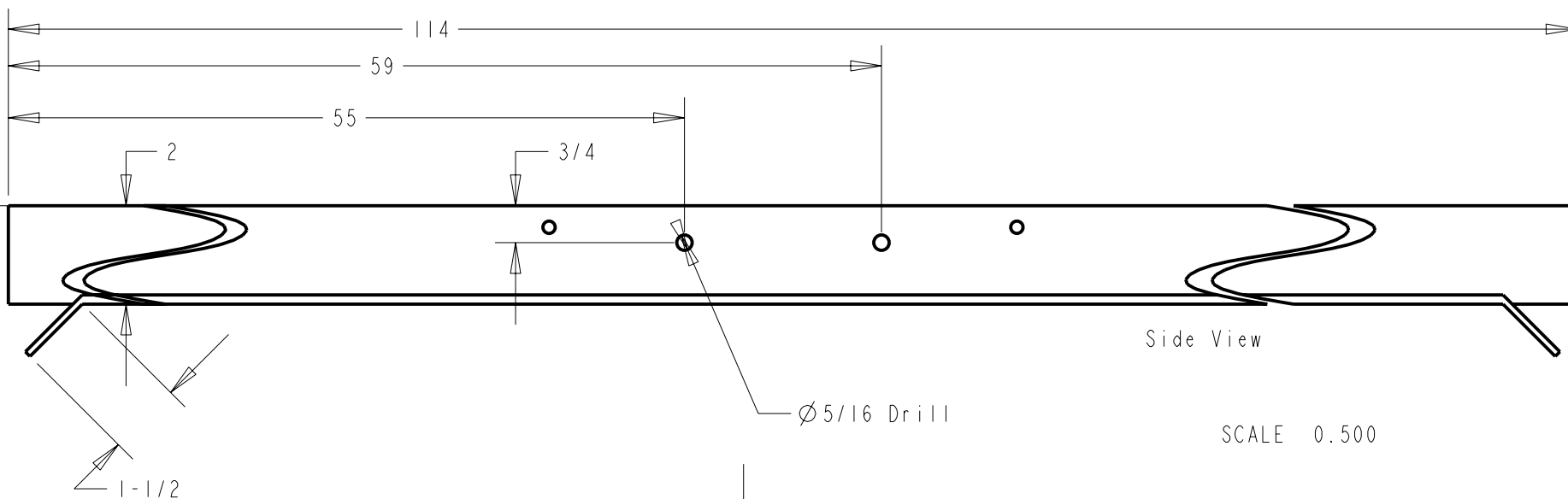
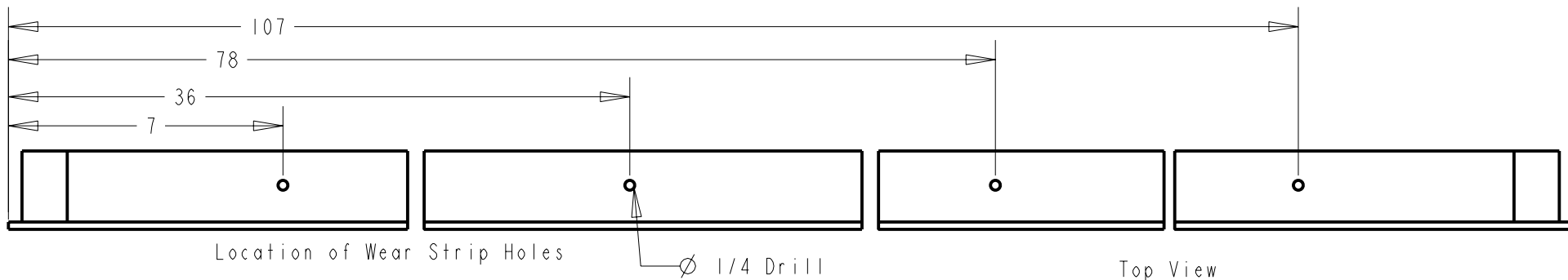

NCSU BAE      Date: 10-21-05      DWG# 1aBC

All Dimensions In Inches

Project: Burley Stripping Conveyor

Dr By: Justin Macialek

Part No. IBC

Rev. 3-15-06

Part Name: Conveyor Angle

Tolerances x.xx ±.02, x.xxx± .005

Qty. Required: 2

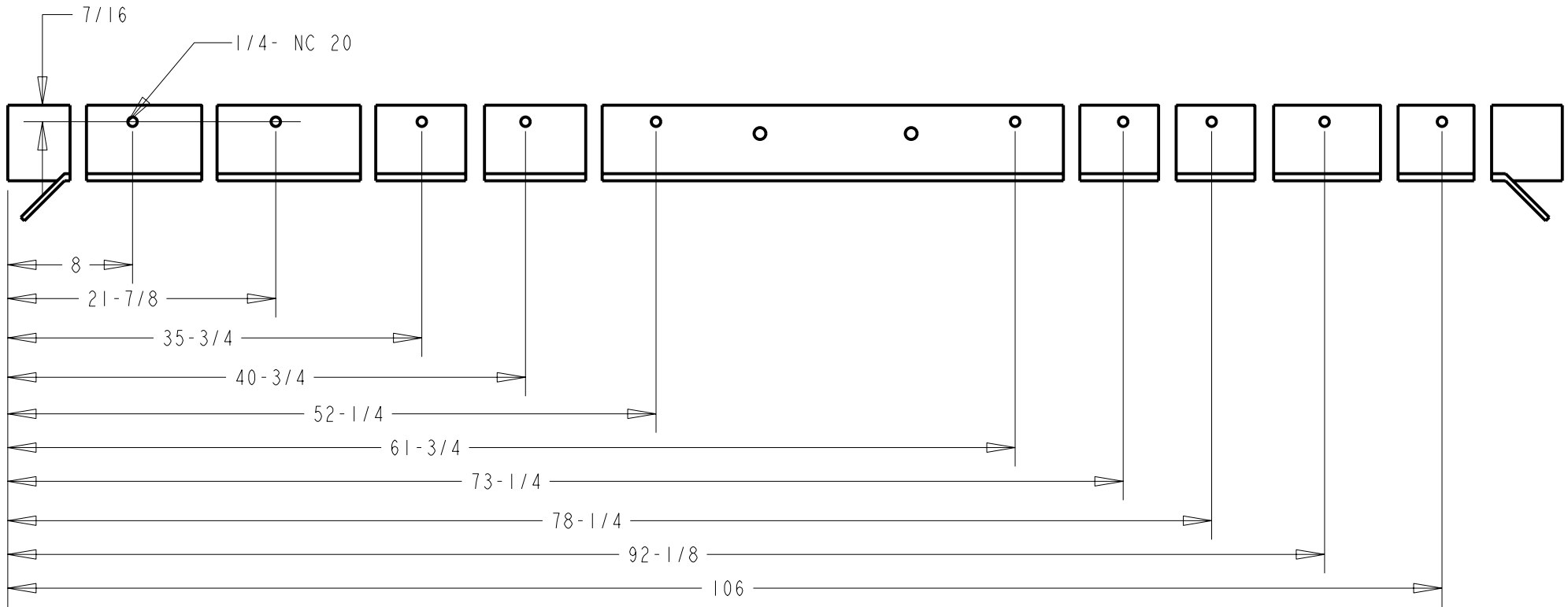

NCSU BAE	Date: 3-14-06	DWG# 1bBC
----------	---------------	-----------

All Dimensions In Inches

Project: Burley Stripping Conveyor	Dr By: Justin Macialek	Part No. IBC	Rev. 3-14-06
Part Name: Conveyor Angle, Shield Mount Holes	Tolerances x.xx ±.02, x.xxx± .005		Qty. Required: 2

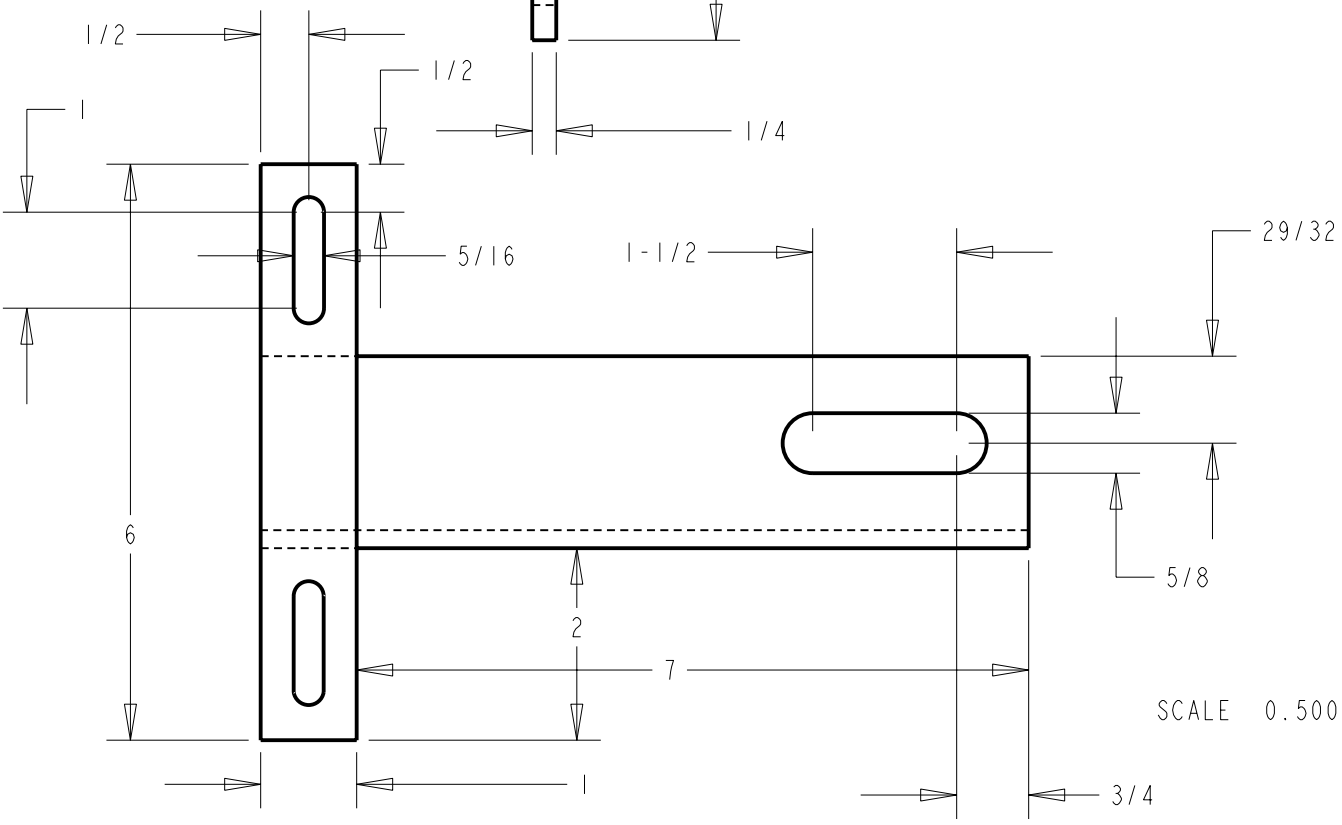
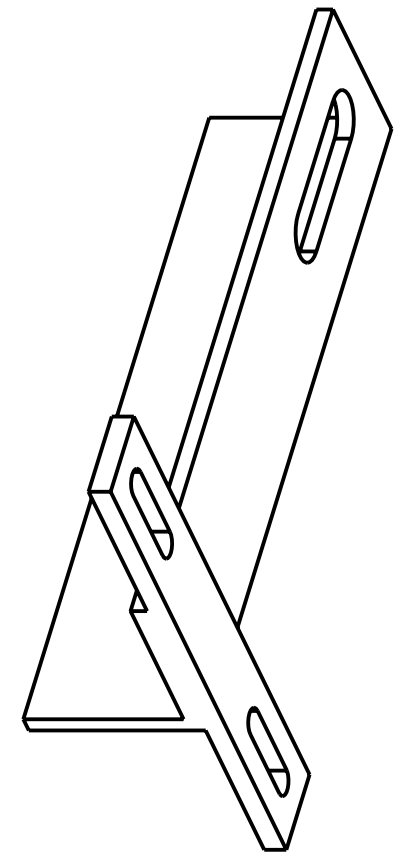
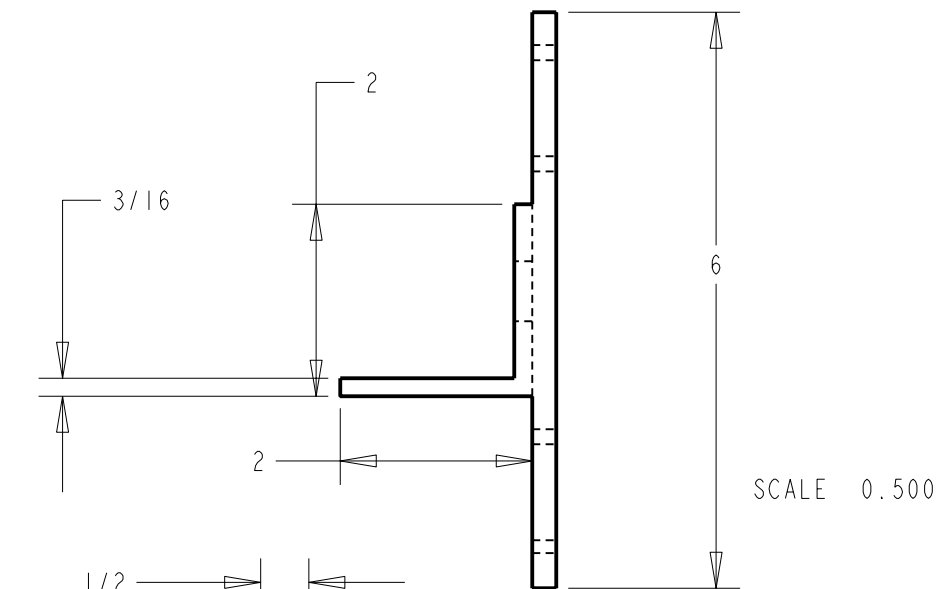

NCSU BAE	Date: 10-24-05	DWG# 4aBC	All Dimensions In Inches	
Project: Burley Stripping Conveyor		Dr By: Justin Macialek	Part No. 4BC	Rev. 10-24-05
Part Name: Chain Support		Tolerances $x.xx \pm .02$ , $x.xxx \pm .005$		Qty. Required: 2



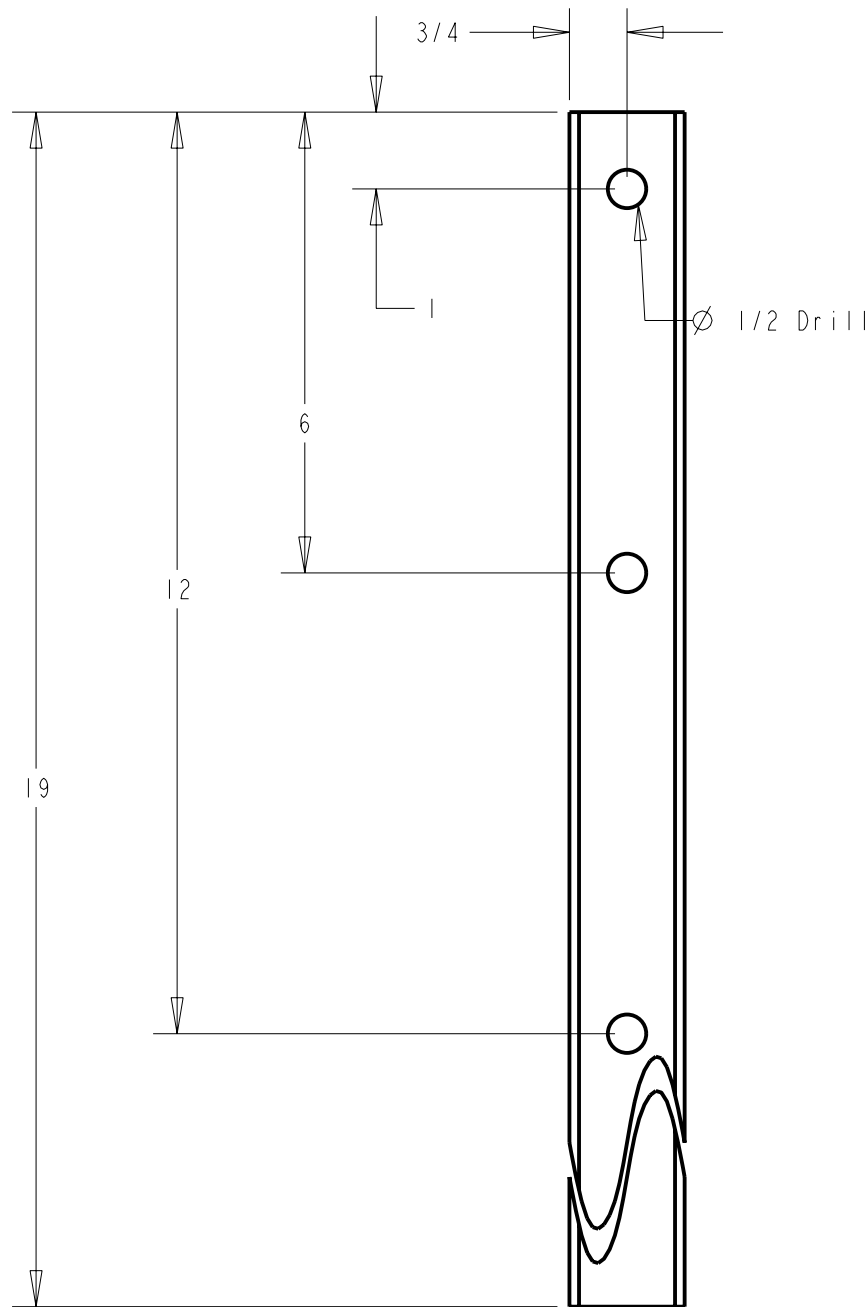
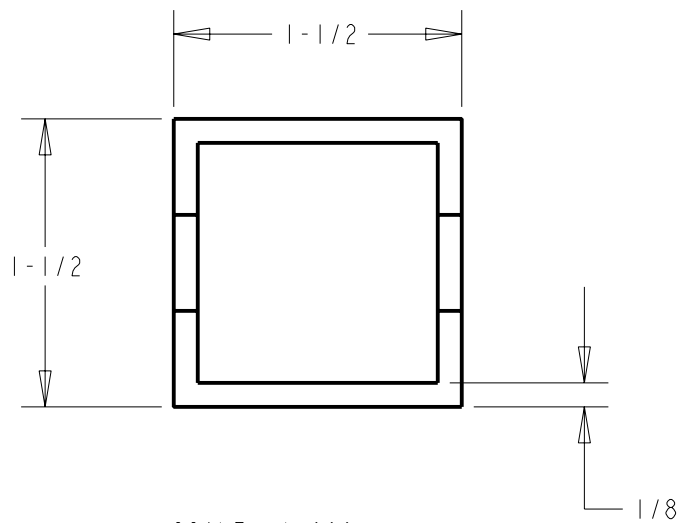

NCSU BAE	Date: 10-21-05	DWG# 5aBC
----------	----------------	-----------

All Dimensions In Inches

Project: Burley Stripping Conveyor	Dr By: Justin Macialek	Part No. 5BC	Rev. 11-21-05
------------------------------------	------------------------	--------------	---------------

Part Name: Lower Leg	Tolerances x.xx ±.02, x.xxx± .005	Qty. Required: 4
----------------------	-----------------------------------	------------------

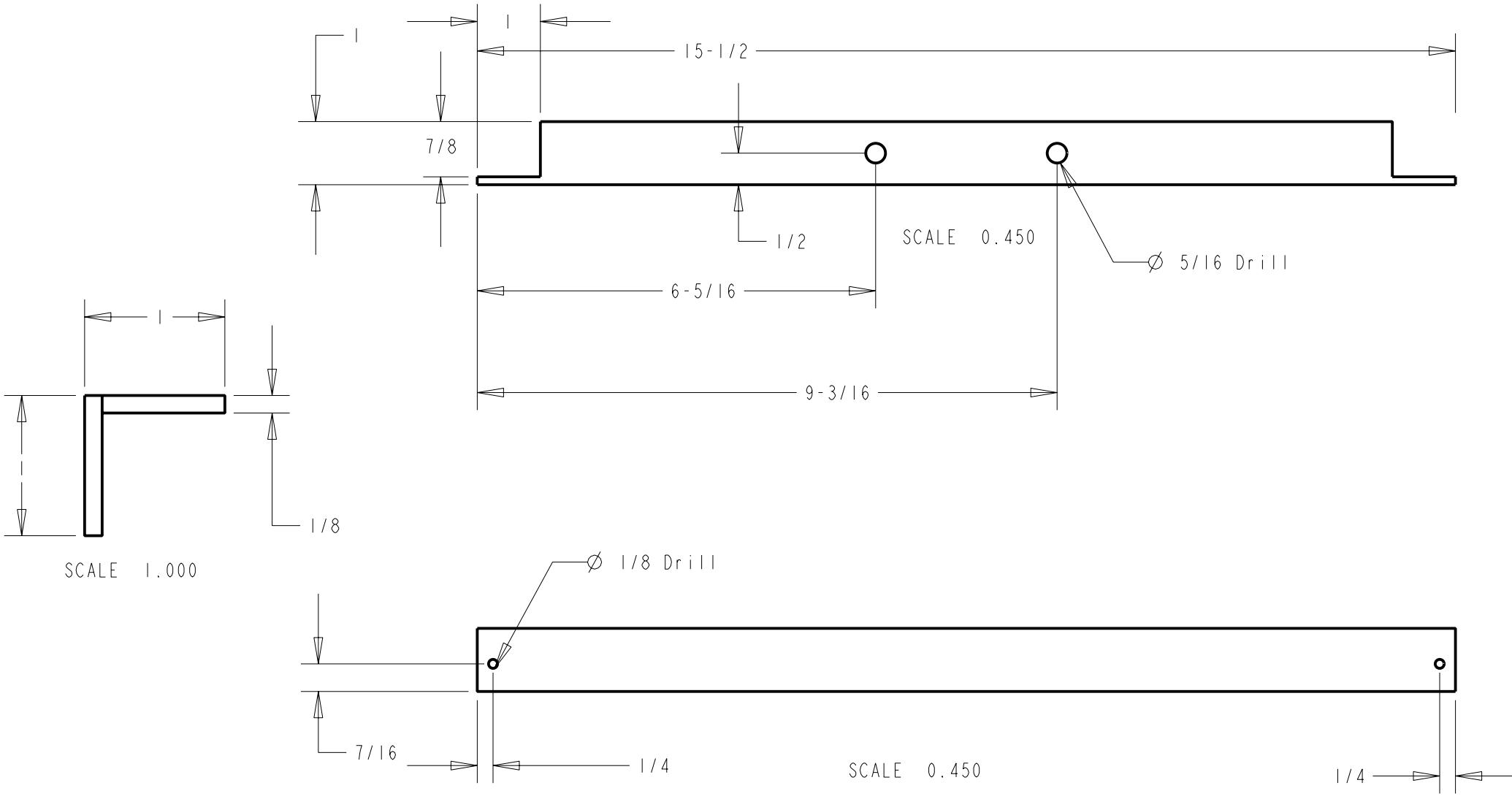

NCSU BAE	Date: 10-24-05	DWG# 7aBC
----------	----------------	-----------

All Dimensions In Inches

Project: Burley Stripping Conveyor

Dr By: Justin Macialek

Part No. 7BC

Rev. 3-10-06

Part Name: Chain Crossbar

Tolerances x.xx ±.02, x.xxx± .005

Qty. Required: 11

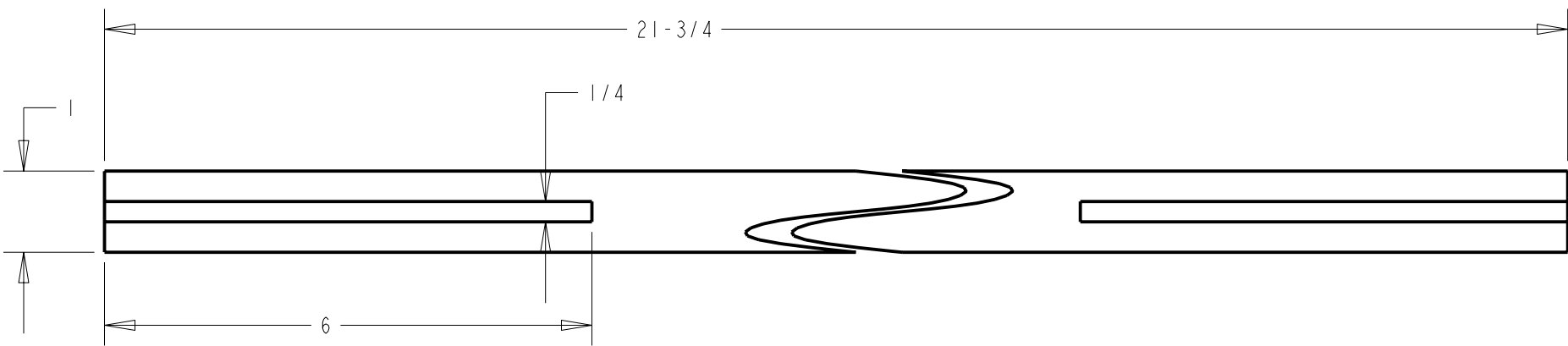

NCSU BAE	Date: 11-21-05	DWG# 8aBC
----------	----------------	-----------

All Dimensions In Inches

Project: Burley Stripping Conveyor

Dr By: Justin Macialek

Part No. 8BC

Rev. 3-16-06

Part Name: linch Idler Shaft

Tolerances  $x.xx \pm .02$ ,  $x.xxx \pm .005$

Qty. Required: 1

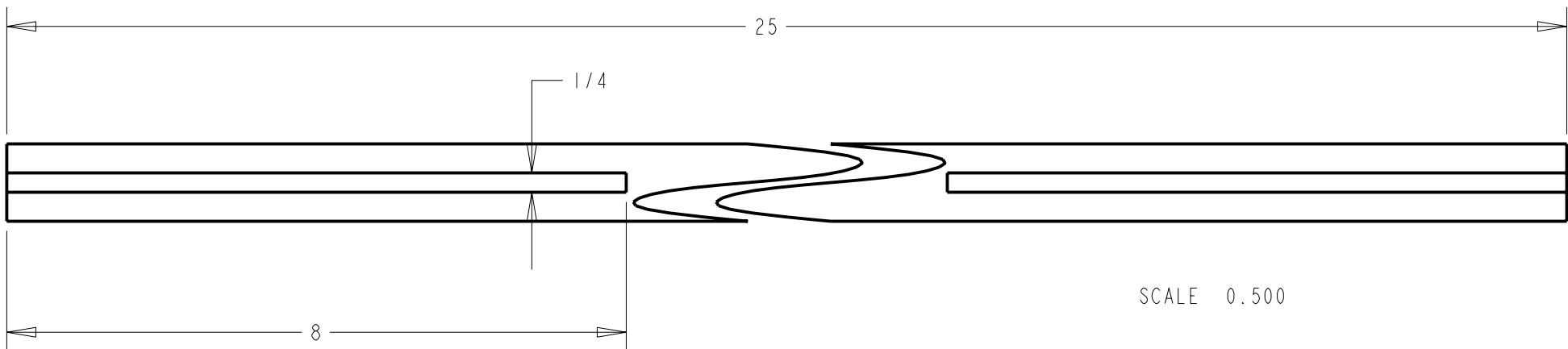

SCALE 0.500

NCSU BAE	Date: 11-21-05	DWG# 9aBC
----------	----------------	-----------

All Dimensions In Inches

Project: Burley Stripping Conveyor

Dr By: Justin Macialek

Part No. 9BC

Rev. 11-21-05

Part Name: linch Drive Shaft

Tolerances x.xx ±.02, x.xxx± .005

Qty. Required: 1

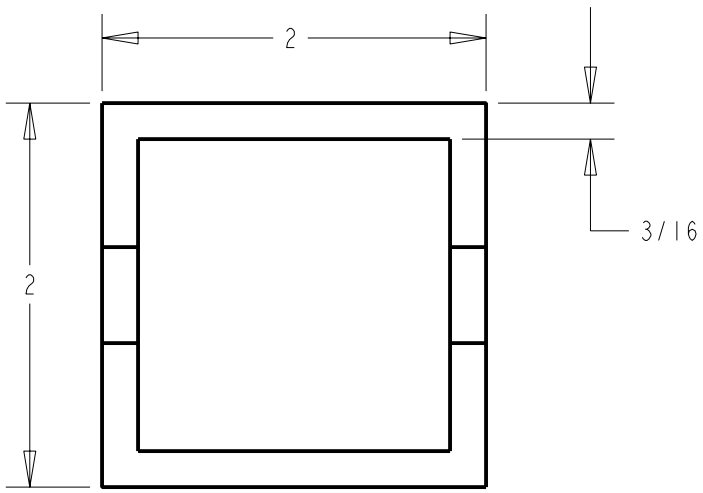

SCALE 1.000

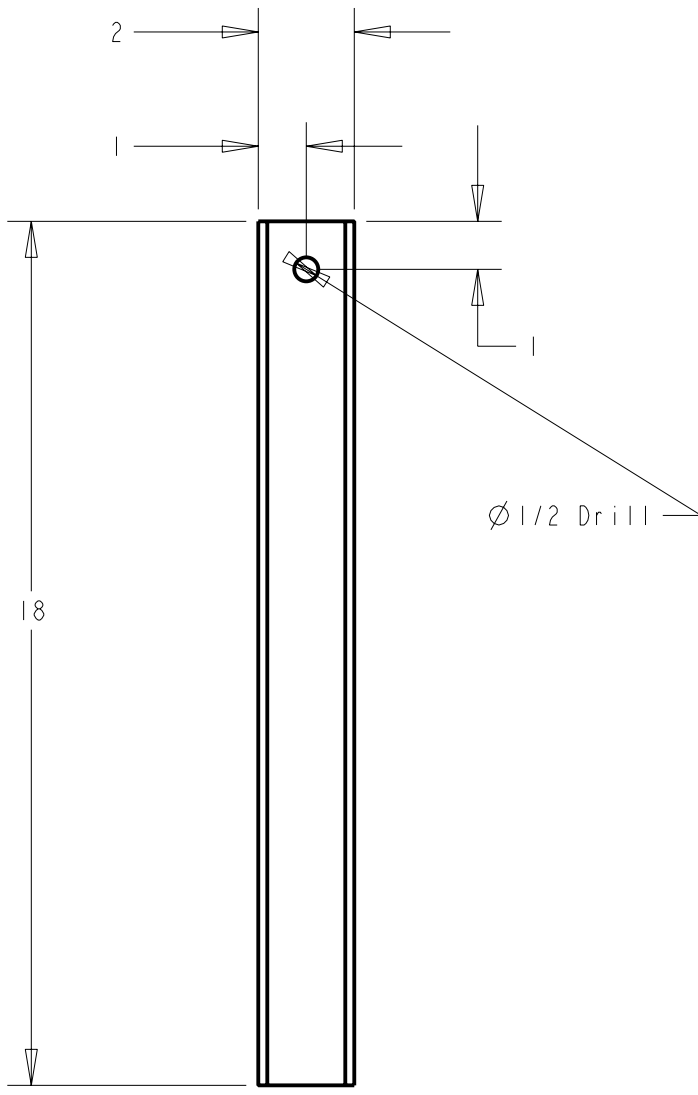

SCALE 0.250

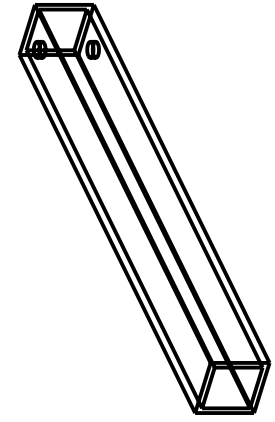

NCSU BAE	Date: 10-24-05	DWG# 11aBC
----------	----------------	------------

All Dimensions In Inches

Project: Burley Stripping Conveyor

Dr By: Justin Macialek

Part No. 11BC

Rev. 11-21-05

Part Name: Upper Leg

Tolerances x.xx ±.02, x.xxx± .005

Qty. Required: 4

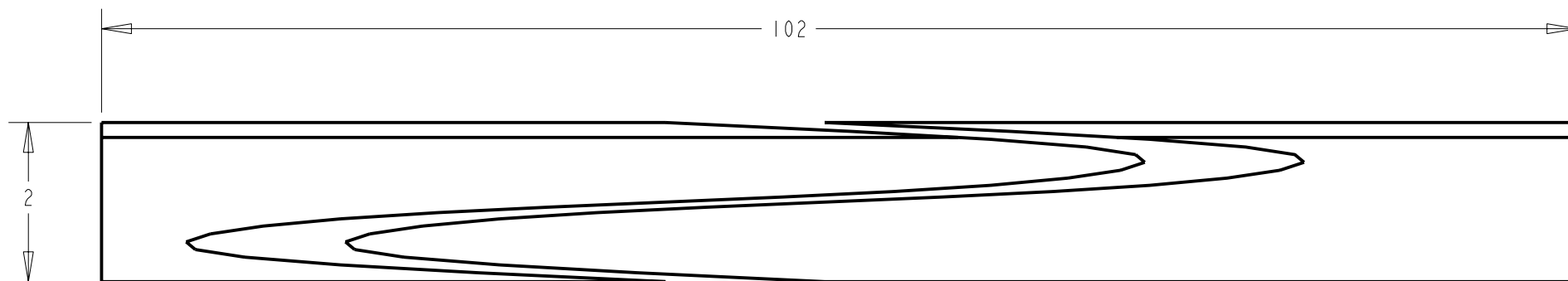
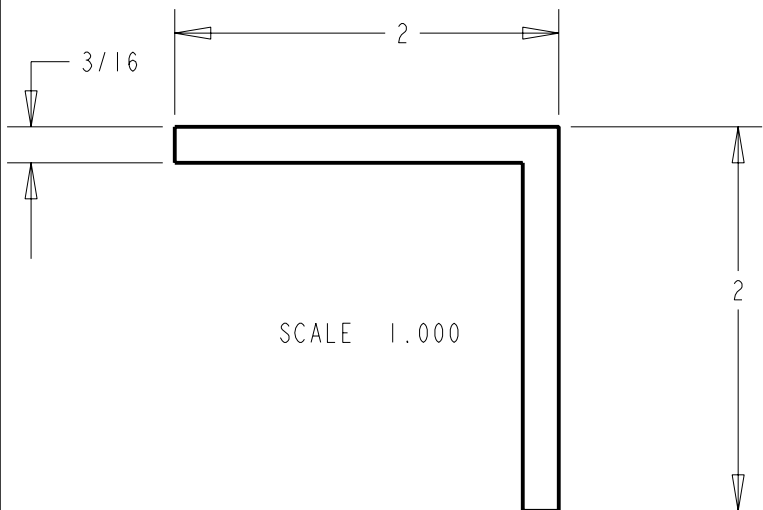

NCSU BAE	Date: 10-25-05	DWG# 12aBC
----------	----------------	------------

All Dimensions In Inches

Project: Burley Stripping Conveyor

Dr By: Justin Macialek

Part No. 12BC

Rev. 11-21-05

Part Name: Upper Leg 10 ft Crossmember

Tolerances x.xx ±.02, x.xxx± .005

Qty. Required: 2

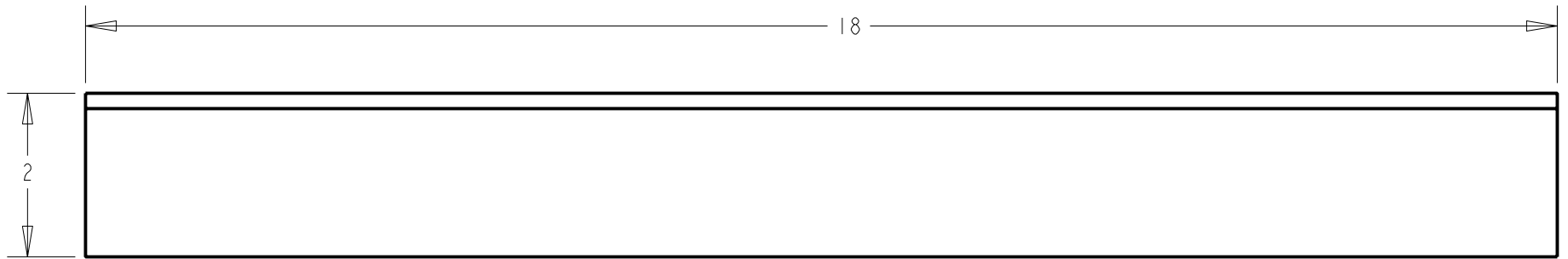
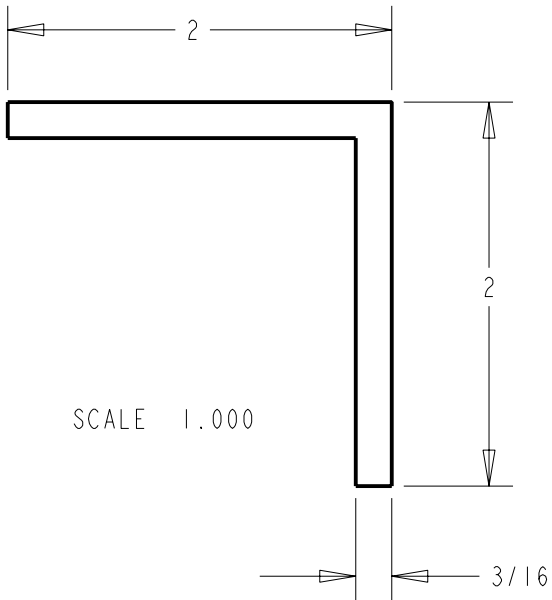

NCSU BAE	Date: 10-25-05	DWG# 13aBC
----------	----------------	------------

All Dimensions In Inches

Project: Burley Stripping Conveyor	Dr By: Justin Macialek	Part No. 13BC	Rev. 10-25-05
------------------------------------	------------------------	---------------	---------------

Part Name: Upper Leg 18in Crossmember	Tolerances x.xx ±.02, x.xxx± .005	Qty. Required: 2
---------------------------------------	-----------------------------------	------------------

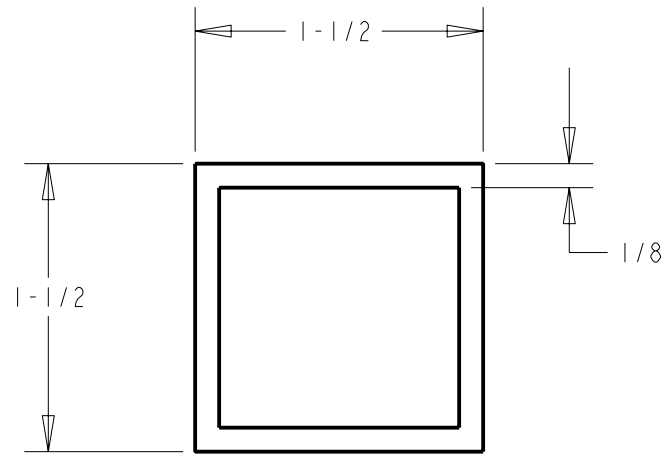

SCALE 1.000

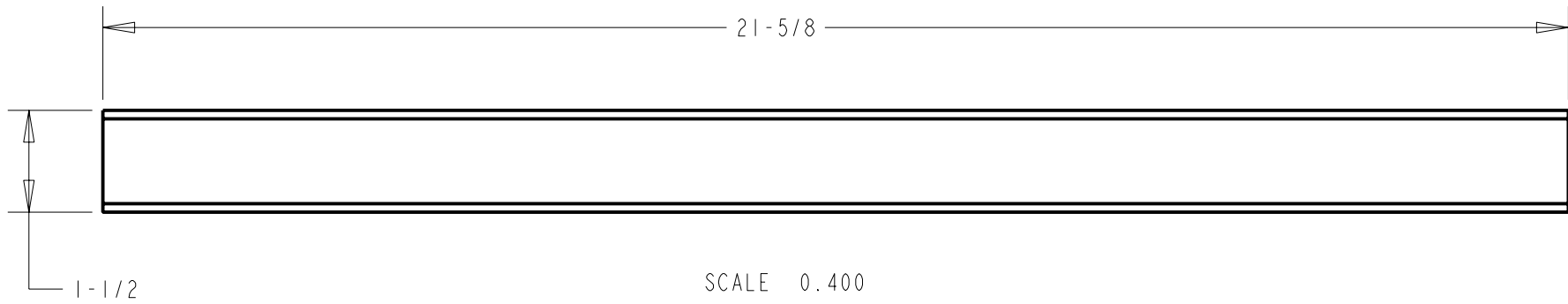

SCALE 0.400

All Dimensions In Inches

NCSU BAE Date: 10-25-05 DWG# 14aBC

Project: Burley Stripping Conveyor

Dr By: Justin Macialek

Part No. 14BC

Rev. 11-21-05

Part Name: Upper Leg Crossmember

Tolerances x.xx ±.02, x.xxx± .005

Qty. Required: 1



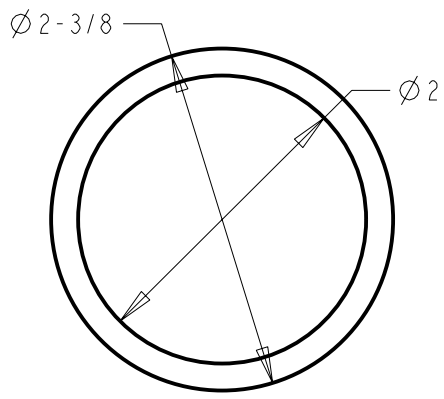

SCALE 0.750

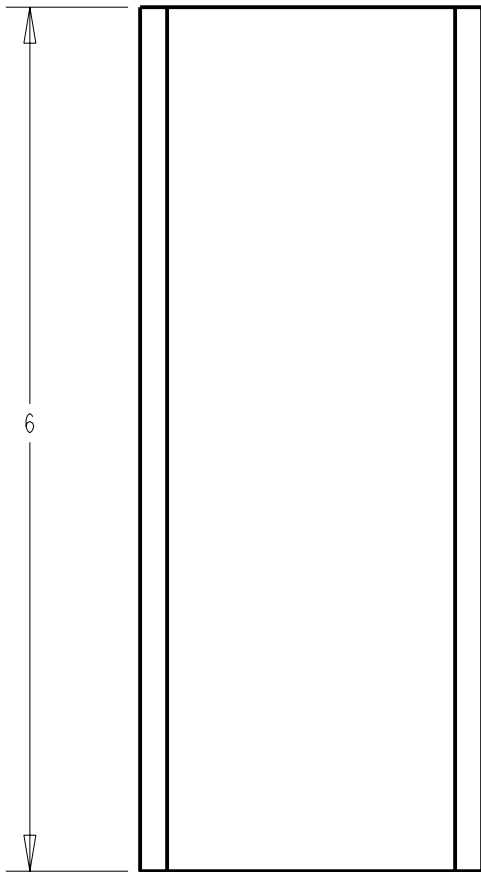
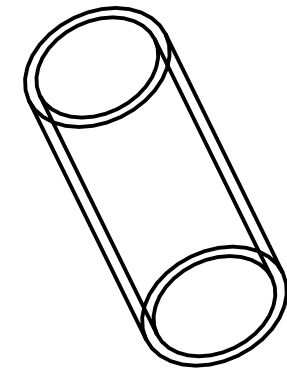

All Dimensions In Inches

NCSU BAE	Date: 11-21-05	DWG# 17aBC
----------	----------------	------------

Project: Burley Stripping Conveyor

Dr By: Justin Macialek

Part No. 17BC

Rev. 11-21-05

Part Name: PVC Plant Holder

Tolerances x.xx ±.02, x.xxx± .005

Qty. Required: 11

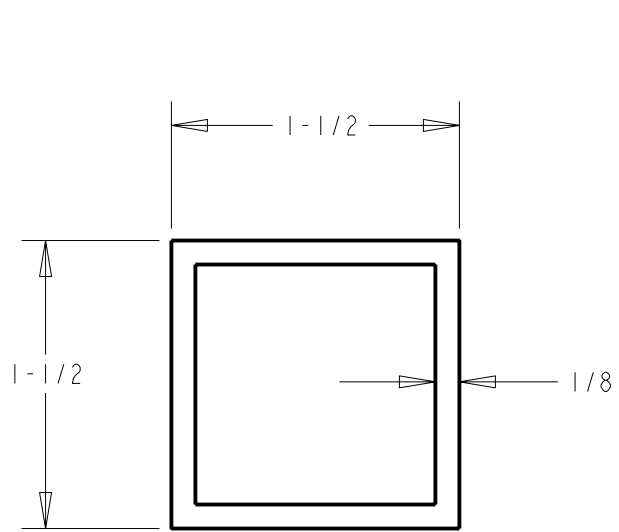

SCALE 1.000

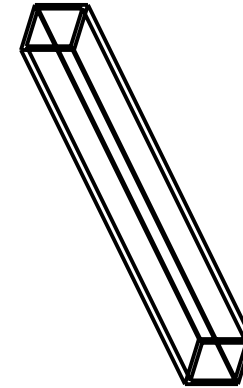
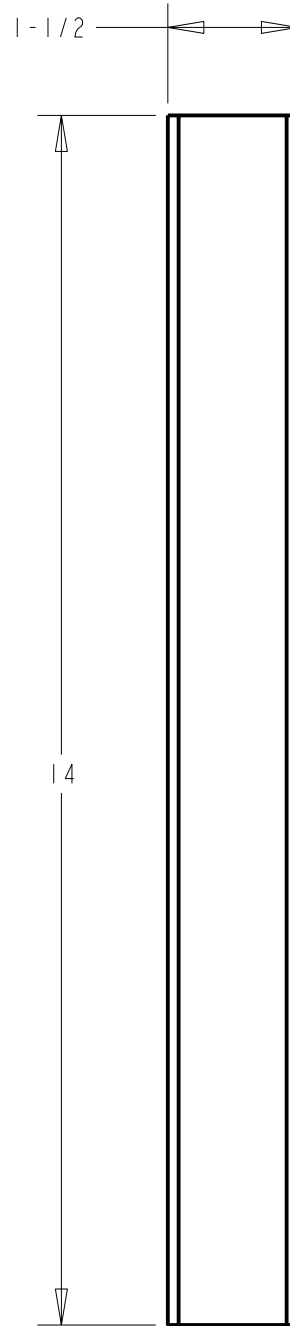

SCALE 0.450

NCSU BAE	Date: 10-25-05	DWG# 20aBC
----------	----------------	------------

All Dimensions In Inches

Project: Burley Stripping Conveyor	Dr By: Justin Macialek	Part No. 20BC	Rev. 11-21-05
------------------------------------	------------------------	---------------	---------------

Part Name: Conveyor Support	Tolerances x.xx ±.02, x.xxx± .005	Qty. Required: 4
-----------------------------	-----------------------------------	------------------

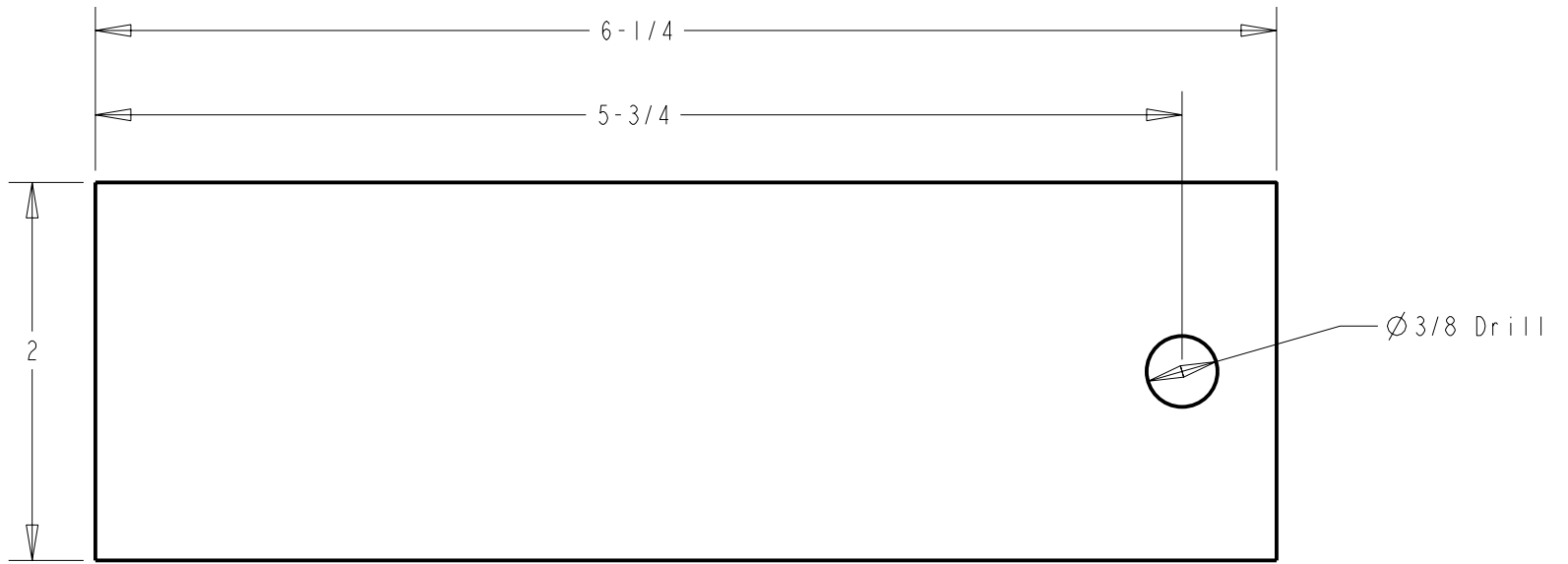

SCALE 1.000

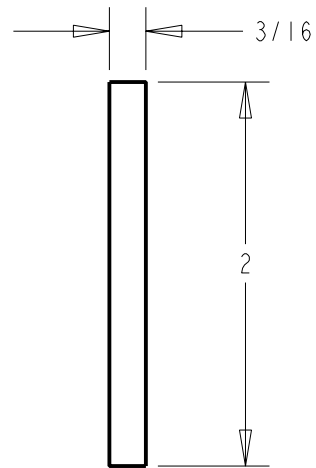

SCALE 1.000

NCSU BAE	Date: 11-18-05	DWG# 22aBC	All Dimensions In Inches	
Project: Burley Stripping Conveyor		Dr By: Justin Macialek		Part No. 22BC
Part Name: Upper Bearing Mount		Tolerances x.xx ±.02, x.xxx± .005		Rev. 11-18-05
				Qty. Required: 4

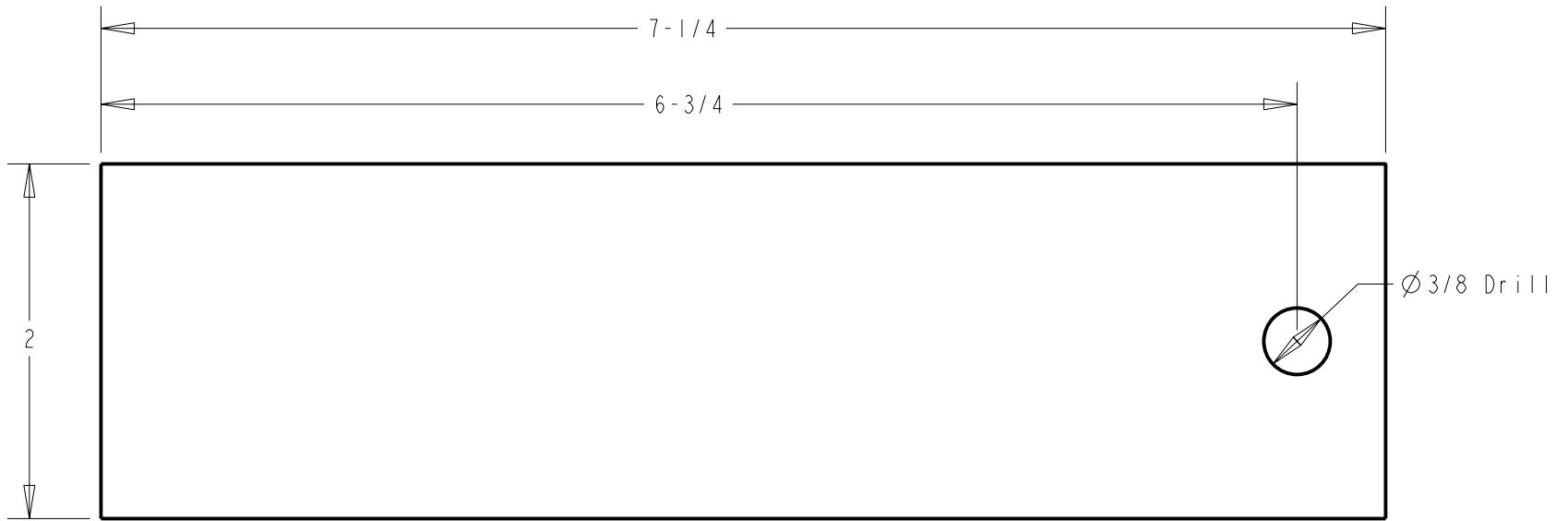

SCALE 1.000

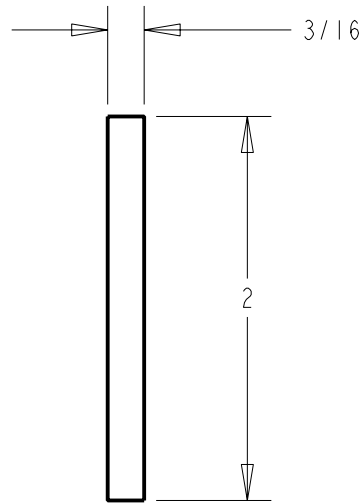

SCALE 1.000

NCSU BAE	Date: 11-18-05	DWG# 23aBC	All Dimensions In Inches	
Project: Burley Stripping Conveyor		Dr By: Justin Macialek		Part No. 23BC
Part Name: Lower Bearing Mount		Tolerances x.xx ±.02, x.xxx± .005		Qty. Required: 4
Rev. 11-18-05				

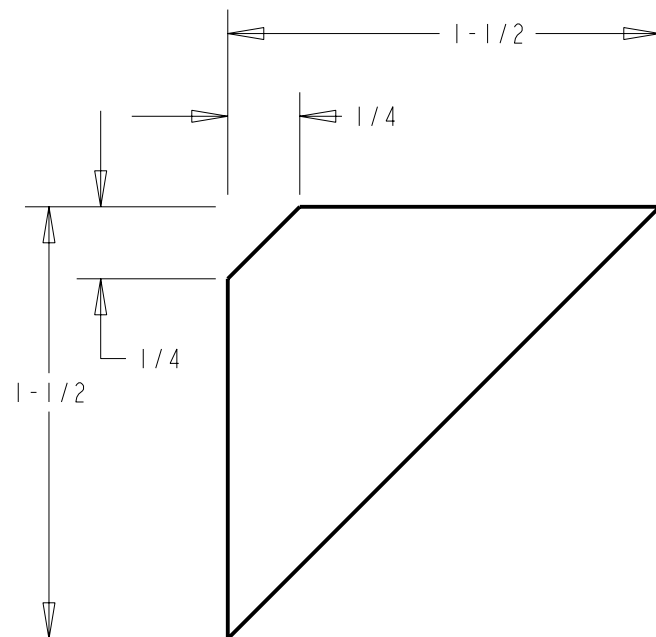

3/16 inch Thickness

SCALE 1.500

NCSU BAE	Date: 11-18-05	DWG# 24aBC
----------	----------------	------------

All Dimensions In Inches

Project: Burley Stripping Conveyor	Dr By: Justin Macialek	Part No. 24BC	Rev. 3-16-06
------------------------------------	------------------------	---------------	--------------

Part Name: Lower Bearing Mount Gusset	Tolerances x.xx ±.02, x.xxx± .005	Qty. Required: 4
---------------------------------------	-----------------------------------	------------------

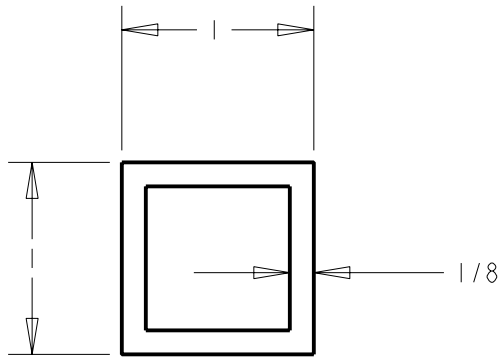

SCALE 1.000

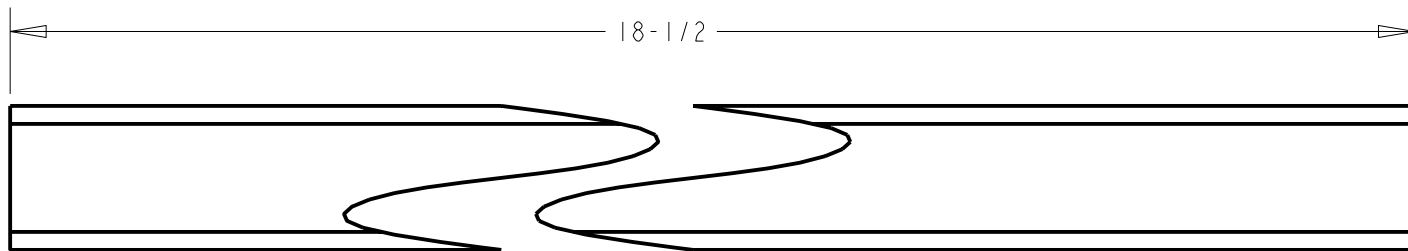

All Dimensions In Inches

NCSU BAE	Date: 11-21-05	DWG# 25aBC
----------	----------------	------------

Project: Burley Stripping Conveyor

Dr By: Justin Macialek

Part No. 25BC

Rev. 11-21-05

Part Name: Lower Leg Brace

Tolerances x.xx ±.02, x.xxx± .005

Qty. Required: 2

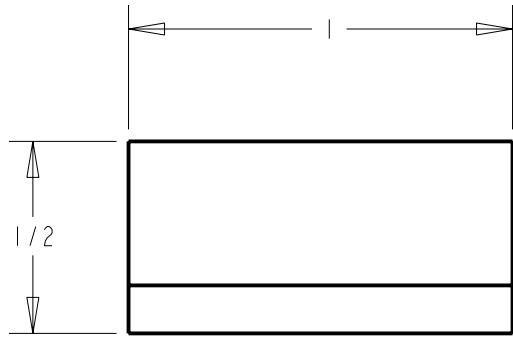

SCALE 2.000

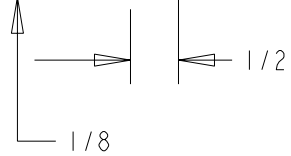
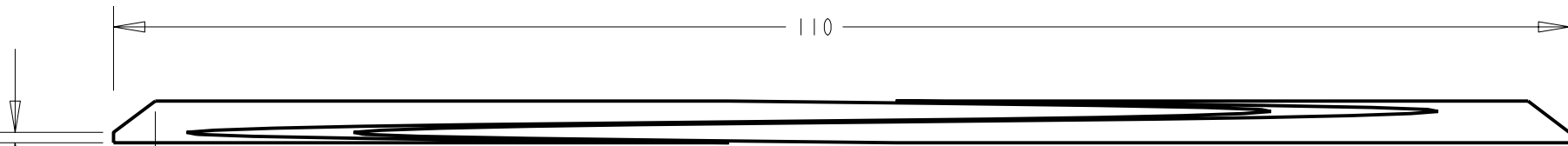

Ø 1/4 Drill, Counter Bore 1/4 inch

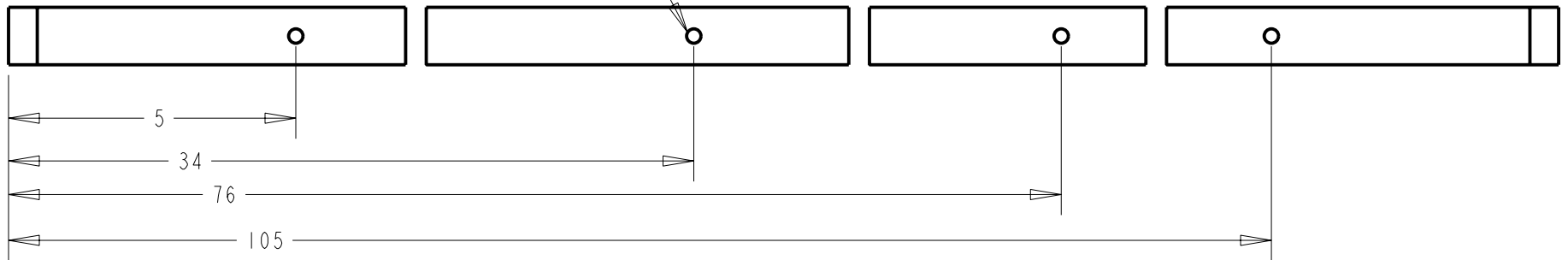

NCSU BAE	Date: 11-21-05	DWG# 26aBC
----------	----------------	------------

All Dimensions In Inches

Project: Burley Stripping Conveyor	Dr By: Justin Macialek	Part No. 26BC	Rev. 3-15-06
------------------------------------	------------------------	---------------	--------------

Part Name: Plastic Wear Strips	Tolerances x.xx ±.02, x.xxx± .005	Qty. Required: 2
--------------------------------	-----------------------------------	------------------

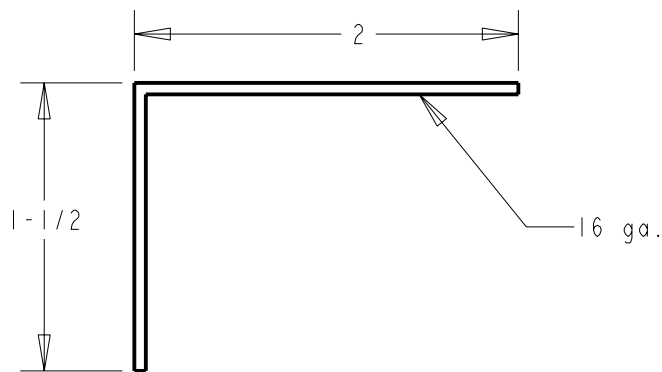
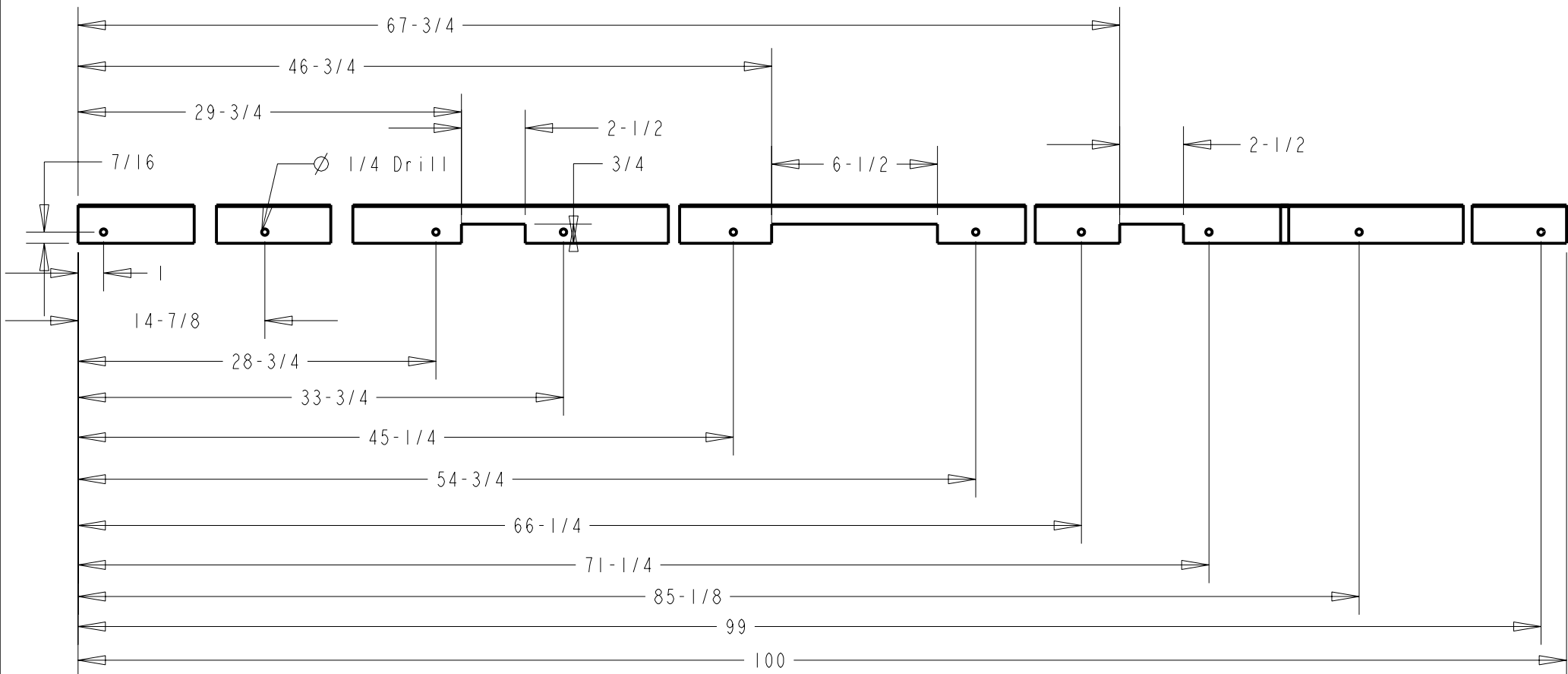

SCALE 1.000

NCSU BAE	Date: 3-14-06	DWG# 27aBC	All Dimensions In Inches	
Project: Burley Stripping Conveyor		Dr By: Justin Macialek		Part No. 27BC
Part Name: Conveyor Angle Shield		Tolerances x.xx ±.02, x.xxx± .005		Rev. 3-14-06
				Qty. Required: 2



SCALE 0.250

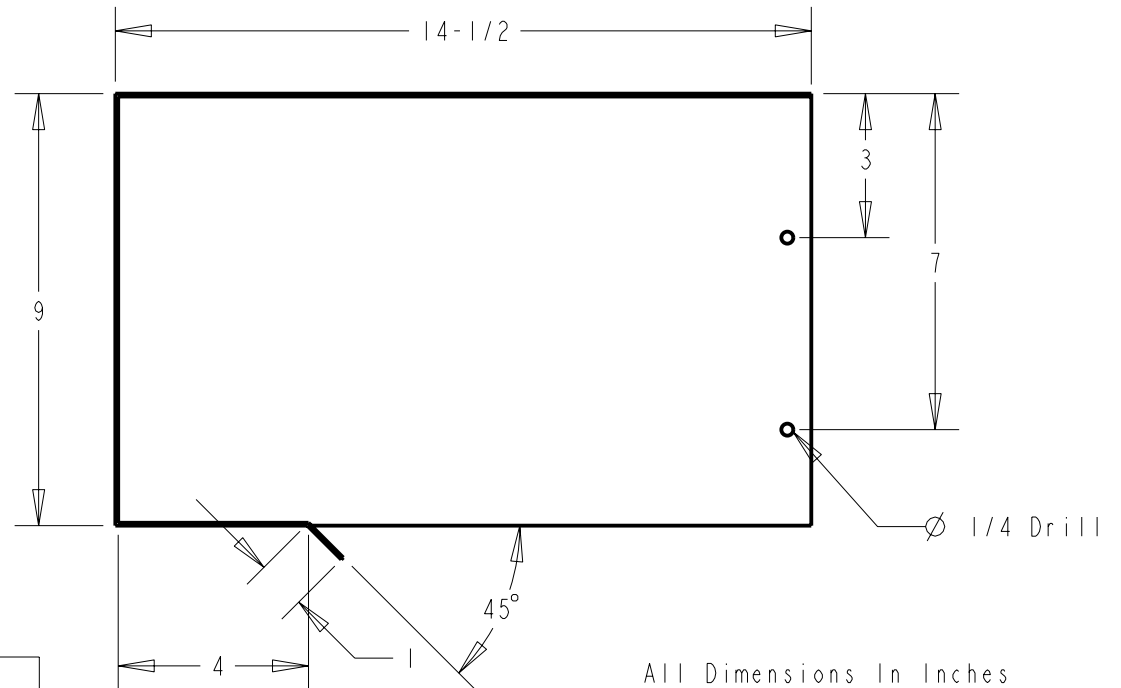
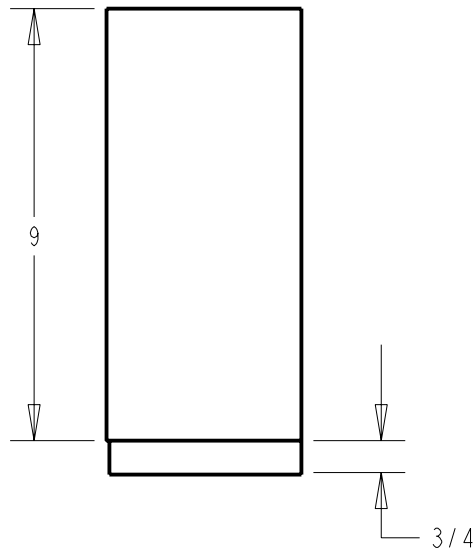
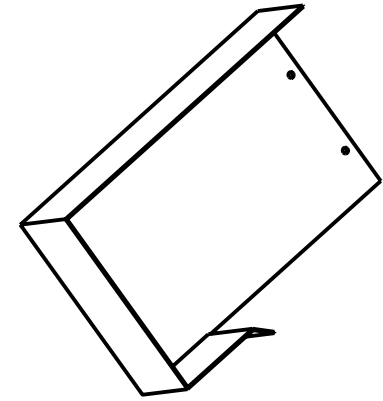
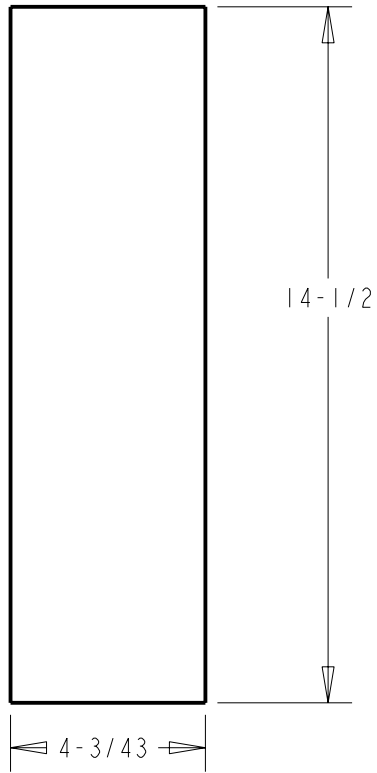

All Dimensions In Inches

NCSU BAE	Date: 3-15-06	DWG# 28BC
----------	---------------	-----------

Project: Burley Stripping Conveyor

Dr By: Justin Macialek

Part No. 28BC

Rev. 3-17-06

Part Name: Sprocket Shield, Left Side

Tolerances x.xx ±.02, x.xxx± .005

Qty. Required: 1

SCALE 0.250

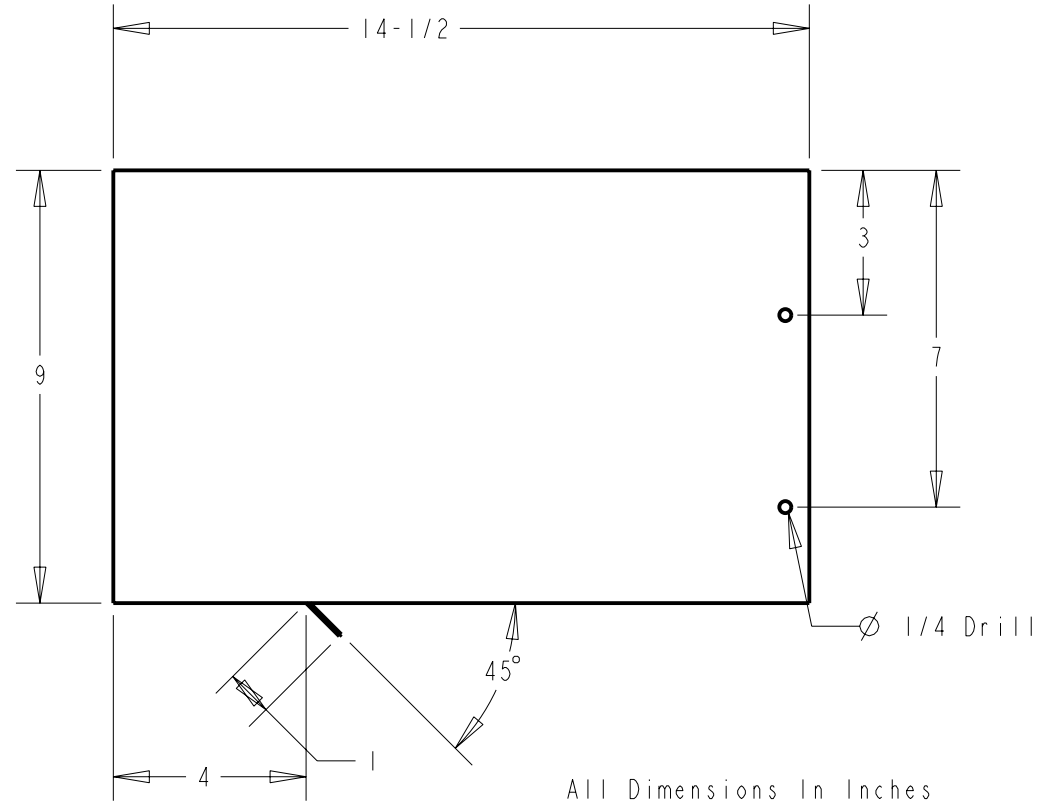
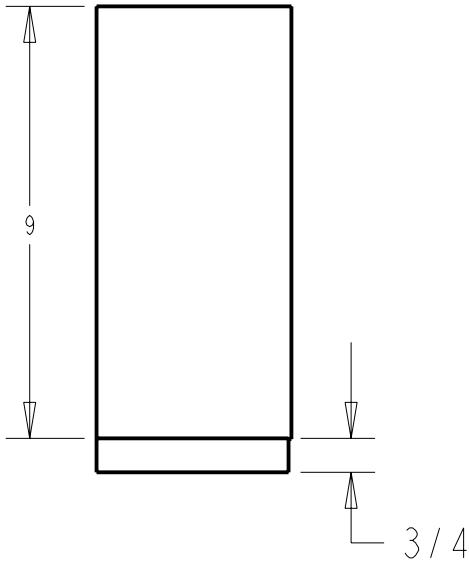
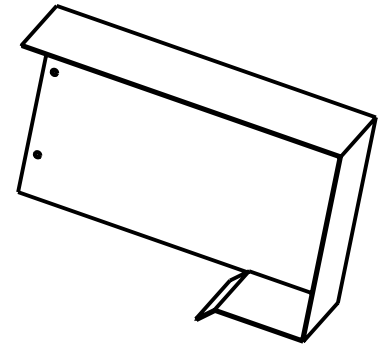
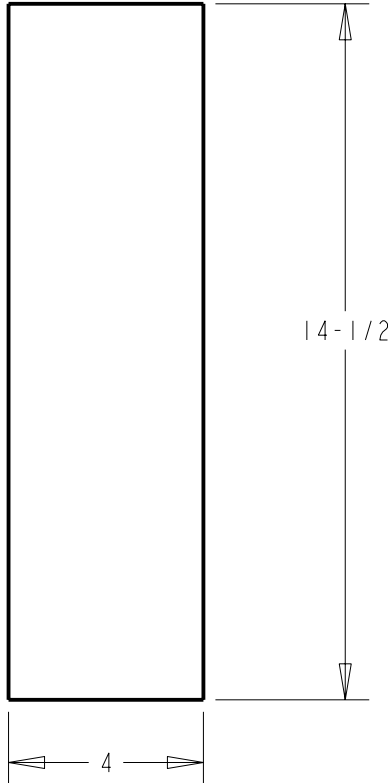

All Dimensions In Inches

NCSU BAE	Date: 3-15-06	DWG# 29BC
----------	---------------	-----------

Project: Burley Stripping Conveyor

Dr By: Justin Macialek

Part No. 29BC

Rev. 3-17-06

Part Name: Sprocket Shield, Right Side

Tolerances x.xx ±.02, x.xxx± .005

Qty. Required: 2

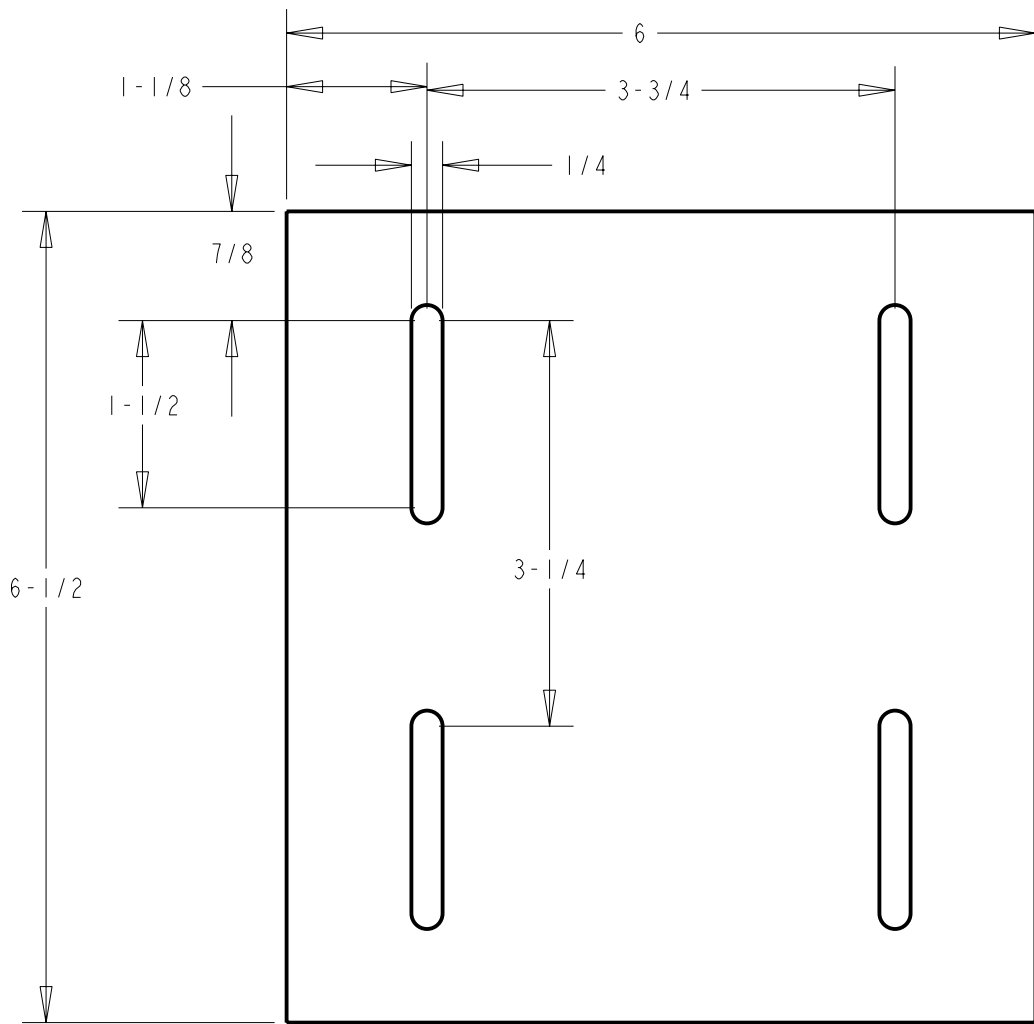

SCALE 0.650

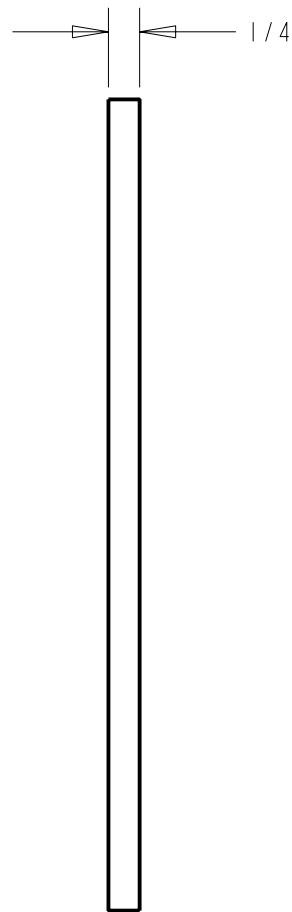

SCALE 0.650

Mount is for Dayton Model #4z283

NCSU BAE	Date: 3-15-06	DWG# 30BC
----------	---------------	-----------

All Dimensions In Inches

Project: Burley Stripping Conveyor	Dr By: Justin Macialek	Part No. 30BC	Rev. 3-16-06
------------------------------------	------------------------	---------------	--------------

Part Name: Motor Mount	Tolerances x.xx ±.02, x.xxx± .005	Qty. Required: 1
------------------------	-----------------------------------	------------------

SCALE 0.200

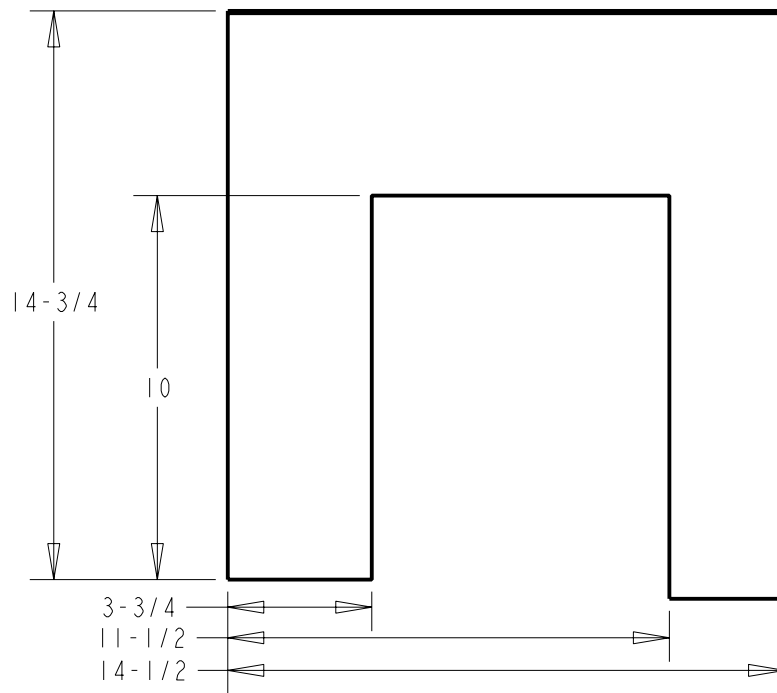
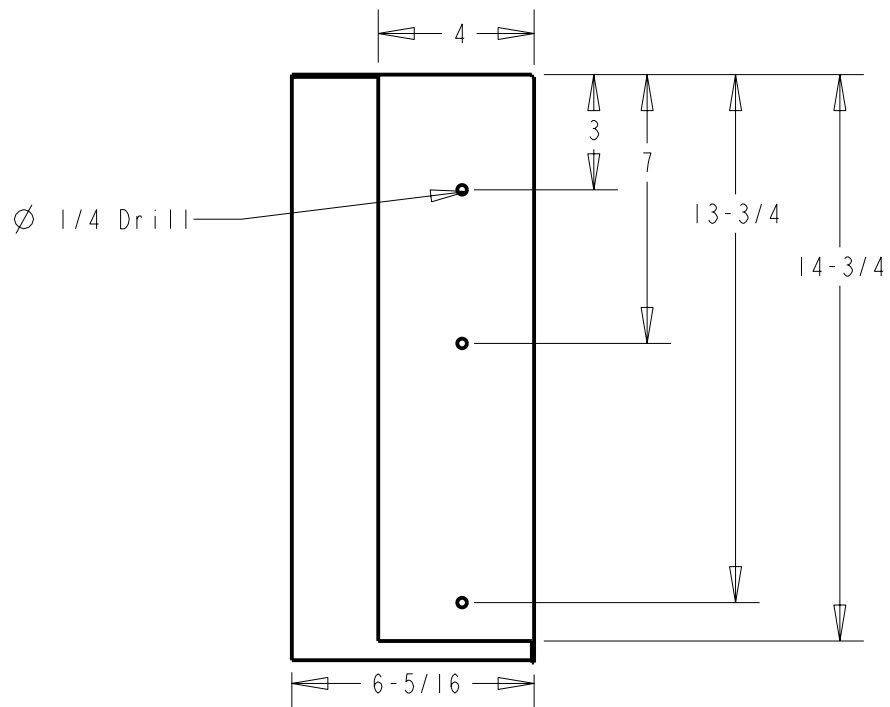
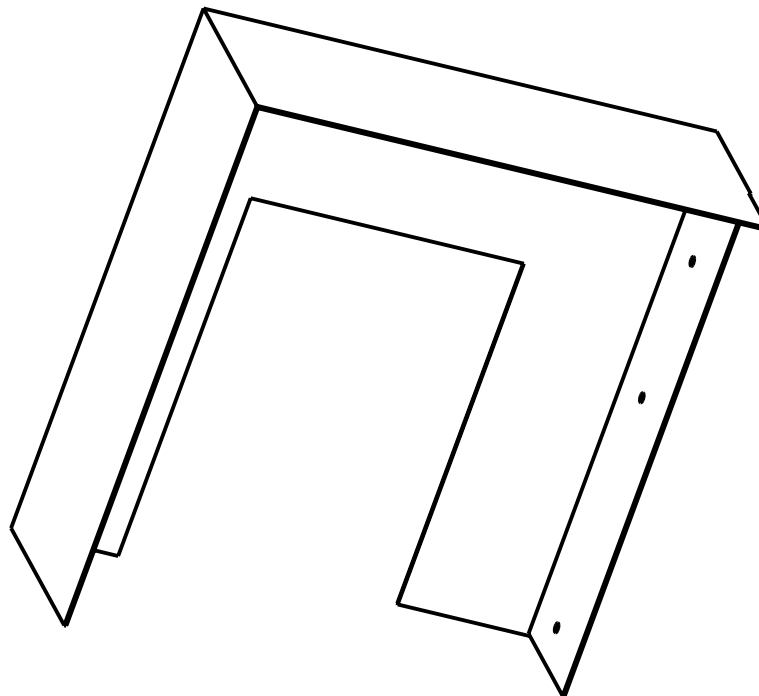
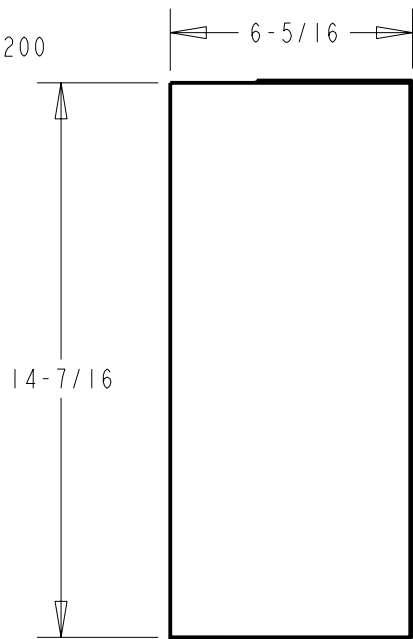

All Dimensions In Inches

NCSU BAE	Date: 3-16-06	DWG# 31BC
----------	---------------	-----------

Project: Burley Stripping Conveyor

Dr By: Justin Macialek

Part No. 31BC

Rev. 3-17-06

Part Name: Drive Sprocket Shield

Tolerances x.xx ±.02, x.xxx± .005

Qty. Required: 1

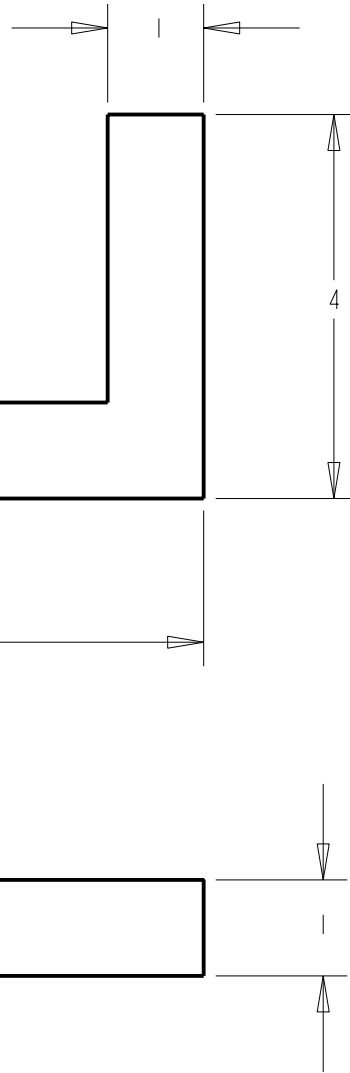

SCALE 0.500

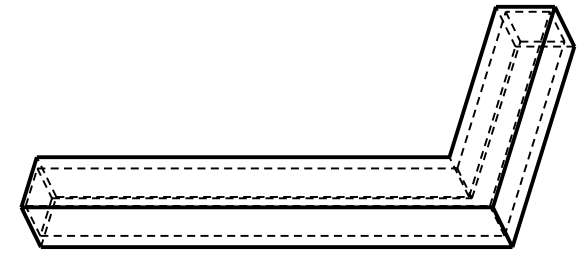

1/8 inch wall thickness

NCSU BAE	Date: 3-15-06	DWG# 32BC
----------	---------------	-----------

All Dimensions In Inches

Project: Burley Stripping Conveyor	Dr By: Justin Macialek	Part No. 32BC	Rev. 3-16-06
------------------------------------	------------------------	---------------	--------------

Part Name: Motor Mount Bracket for Dayton 4z283	Tolerances x.xx ±.02, x.xxx± .005	Qty. Required: 1
---	-----------------------------------	------------------

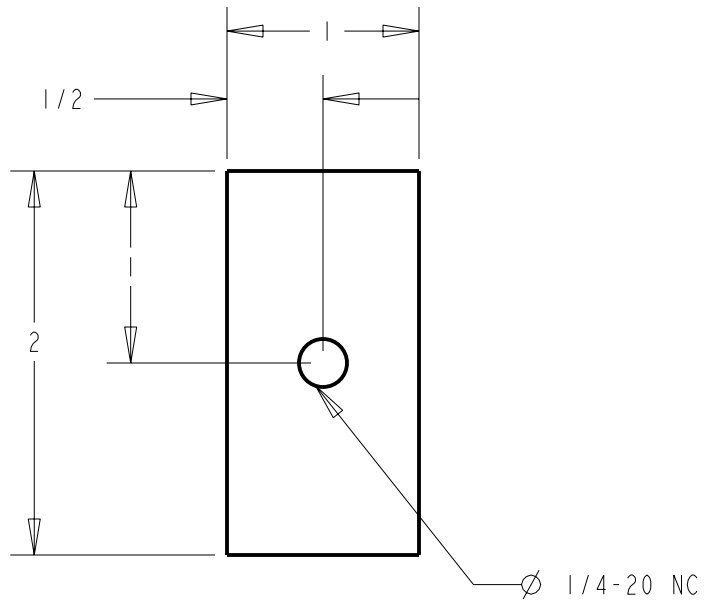
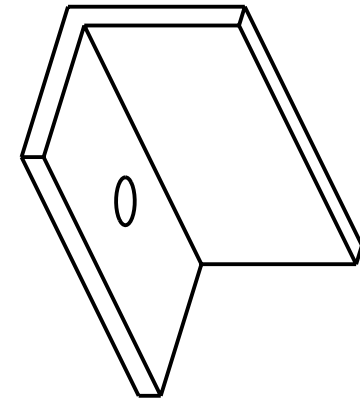
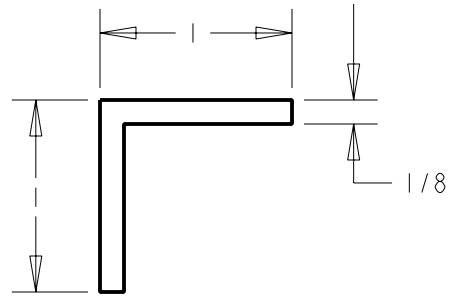

NCSU BAE	Date: 3-15-06	DWG# 33BC
----------	---------------	-----------

All Dimensions In Inches

Project: Burley Stripping Conveyor	Dr By: Justin Macialek	Part No. 33BC	Rev. 3-15-06
------------------------------------	------------------------	---------------	--------------

Part Name: Shield Mount	Tolerances x.xx $\pm$ .02, x.xxx $\pm$ .005	Qty. Required: 9
-------------------------	---	------------------